

iSS57-20

2.0 NM, NEMA23 Stepper Motor with Integrated Encoder and Drive Board

- n Leadshine hybrid servo control technology
- n No tuning requirement and easy-to-use
- n Compact size saving mounting space and setup time
- n Close-loop control eliminating losing of steps
- n Internal optical encoder for accurate position control
- n High starting torque and fast response
- n Smooth motion and super-low motor noise
- n Dynamic current adjustment reducing motor heating
- n Input voltage from 20 to 50 VDC
- n NEMA23 motor with 2.0Nm holding torque
- n Isolated control inputs including Pulse, Direction and Enable
- n In-position and alarm signal output
- n 16 selectable micro steps or software programmable, up to 102,400
- n Over voltage, over-current and position-error protection



Descriptions

The iSS57-20 is a NEMA23 stepper motor with integrated encoder and drive board. Compared with traditional discrete motor and drive, its compact size saves the mounting space of the machine and reduces setup time during the assembling process. Its drive board adopts Leadshine's latest hybrid servo control technology, offering high starting torque, smooth motion and super-low motor noise at low speed. Its output current is dynamically controlled depending on the load condition thus greatly reducing the motor heating. Its internal encoder offers actual motor shaft position information and eliminates the possibility of losing steps. In addition, it can output the in-position and alarm signal like servos for complete system control.

Applications

The iSS57-20 offers an alternative for applications requiring high performance and compact size. Its great feature of fast response and no hunting make it ideal for applications such as bonding and vision systems in which rapid motions with a short distance are required and hunting would be a problem. And it is ideal for applications where the equipment uses a belt-drive mechanism or otherwise has low rigidity and you don't want it to vibrate when stopping.

Specifications

Electrical Specifications

Parameter	Min	Typical	Max	Unit
Input Voltage	20	36	50	VDC
Output Current	0	-	6.0(Peak)	A
Pulse Input Frequency	0	200	500	kHz
Pulse Voltage	0	5	24	V
Logic Signal Current	7	10	16	mA
Isolation Resistance	100	-	-	MΩ

Operating Environment

Cooling	Natural Cooling or Forced cooling	
Operating Environment	Environment	Avoid dust, oil fog and corrosive gases
	Ambient Temperature	0°C – 40°C (32°F – 104°F)
	Humidity	40%RH – 90%RH
	Operating Temperature (Heat Sink)	70°C (158°F) Max
Storage Temperature	-20°C – 65°C (-4°F – 149°F)	

Mechanical Specifications

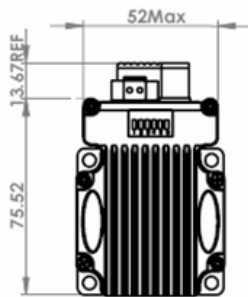

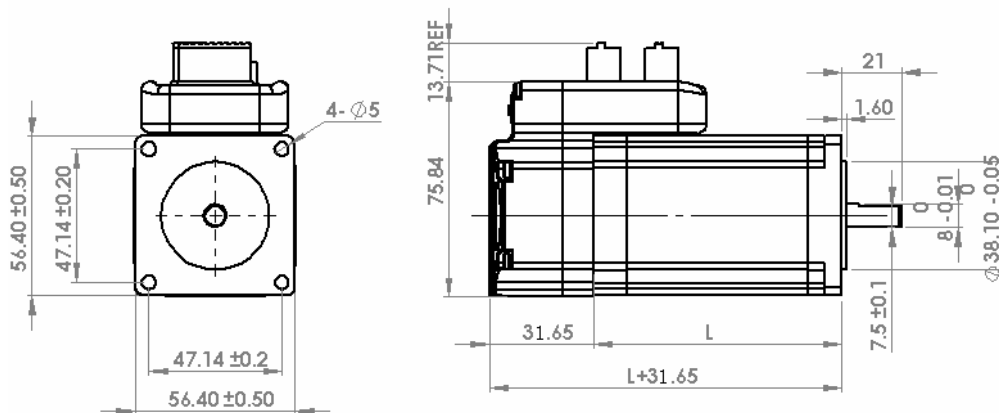

Part Number	Holding Torque	Motor Length (L)	Length of Motor + Drive	Weight
iSS57-20	2.0Nm	80mm	111.65mm	1280g

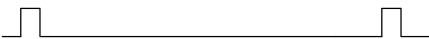
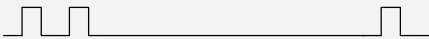

Protection Indications

The green indicator turns on when power-up. When the drive protection is activated, the red LED blinks periodicity (4S) to indicate the error type. For each blinker, the red LED turns on for 0.2 second and then turns off for 0.3 second.

Priority	Time(s) of Blink	Sequence wave of red LED	Description
1st	1		Over-current protection activated when $I_{peak} > 18A$
2nd	2		Over-voltage protection activated when $V_{in} \geq 60VDC$
3rd	7		Position following error exceeds the limit

Connectors and Pin Assignment

The iSS57-20 has three connectors, connector for control signals connections, connector for RS232 communication connections and connector for power connections.

Control Signal Connector			
Pin	Name	I/O	Description
1	PUL+	I	<u>Pulse signal</u> : In single pulse (pulse/direction) mode, this input represents pulse signal, active each rising or falling edge (Set by DIP switch S6); In double pulse mode (software configurable), this input represents clockwise (CW) pulse, active both at high level and low level. 2.5-24V when PUL-HIGH, 0-0.5V when PUL-LOW. For reliable response, pulse width should be longer than 2.5 μ s for 200K MAX input frequency or 1 μ s for 500K MAX input frequency.
2	PUL-	I	
3	DIR+	I	<u>Direction Signal</u> : In single-pulse mode, this signal has low/high voltage levels, representing two directions of motor rotation. In double-pulse mode (software configurable), this signal is counter-clock (CCW) pulse, active both at high level and low level. For reliable motion response, DIR signal should be ahead of PUL signal by 5 μ s at least. 2.5-24V when DIR-HIGH, 0-0.5V when DIR-LOW. The motor direction can also be changed by DIP switch S5. Please note that rotation direction is also related to motor-driver wiring match. Exchanging the connection of two wires for a coil to the driver will reverse motion direction.
4	DIR-	I	
5	ENA+	I	<u>Enable signal</u> : This signal is used for enabling/disabling the driver. In default, high level (NPN control signal) for enabling the driver and low level for disabling the driver. Usually left UNCONNECTED (ENABLED) . Please note that the PNP and Differential control signals are on the contrary, namely Low level for enabling. The active level of ENA signal is software configurable.
6	ENA-	I	
7	PED+	O	<u>In-position Signal</u> : OC output signal, activated when actual motor position reaches to target. This port can sink or source MAX 20mA current at 24V. In default, the impedance between PED+ and PED- is high impedance in normal operation and becomes low when the target is reached. The active impedance of in-position signal can be software configurable (See software manual).
8	PED-	O	

9	ALM+	O	Alarm Signal: OC output signal, activated when one of the following protection is activated: over-voltage, over current and position following error. This port can sink or source MAX 20mA current at 24V. In default, the impedance between ALM+ and ALM- is low impedance in normal operation and becomes high when any protection is activated. The active impedance of alarm signal can be software configurable.
10	ALM-	O	

Power Connector

Pin	Name	I/O	Description
1	+Vdc	I	Power Supply Input (Positive) 20-50VDC recommended, leaving rooms for voltage fluctuation and back-EMF during deceleration.
2	GND	GND	Power Ground (Negative)

RS232 Communication Connector

Pin	Name	I/O	Description
1	+5V	O	+5V power output (Note: Do not connect it to PC's serial port)
2	TxD	O	RS232 transmit.
3	GND	GND	Ground.
4	RxD	I	RS232 receive.
5	NC	-	Not connected.

DIP Switch Settings

Micro Step Resolution (S1-S4)

The micro step resolution is set via the 4-bit DIP switch. When it is all on, the micro step resolution is software configurable, meaning that you can change it in the software and save it to the drive. The software configurable micro step can be set from 200 to 102,400 by step 200. If the DIP switch is not all on, the micro step revolution is determined by the following table.

Steps/Revolution	S1	S2	S3	S4
Software Configured (Default 400)	on	on	on	on
800	off	on	on	on
1600	on	off	on	on
3200	off	off	on	on
6400	on	on	off	on
12800	off	on	off	on
25600	on	off	off	on
51200	off	off	off	on
1000	on	on	on	off
2000	off	on	on	off

Micro Step Resolution (S1-S4) (Continued)

Steps/Revolution	S1	S2	S3	S4
Software Configured (Default 400)	on	on	on	on
4000	on	off	on	off
5000	off	off	on	off
8000	on	on	off	off
10000	off	on	off	off
20000	on	off	off	off
40000	off	off	off	off

Motor Shaft Direction (S5)

DIP switch S5 can be used to change the motor shaft rotation direction. Note that the actual direction is also related to the DIR level.

S5	On	Off
	The motor shaft rotation direction is positive.	The motor shaft rotation direction is negative.

Active edge of input pulse (S6)

DIP switch S6 determines the active edge of the pulse signal. The motor shaft moves one micro step for each active pulse edge.

S6	On	Off
	Active rising edge of input pulse	Active falling edge of input pulse

Current Control Detail

The iSS57-20 adopts a built-in high-resolution optical encoder for position feedback and dynamic current adjustment. The drive board can output maximal 6A current for each motor coil. There are two parameters affects the peak value of the actual motor current. One is the holding current percentage and the other is the close-loop current percentage. When there is no pulse sent to the drive, iSS57-20 goes into idle state and the actual motor current is determined by the holding current percentage. During normal operation, iSS57-20 monitors the actual shaft position and changes the motor current which is limited by the close-loop current percentage dynamically, according to the position error between the target and the command.

By default, the holding current percentage is 30% and the close-loop current percentage is 80%, unless you change them in the software (see software manual). Thus the actual current can be calculated as follows:

$$\text{Holding Current} = 6A \times \text{Holding Current Percentage} (\%)$$

$$\text{MAX Close loop Current} = 6A \times \text{Close Loop Current Percentage} (\%)$$

Low holding current can reduce motor heating however also reduces the holding torque which is used to lock the motor shaft at standstill. It is recommended to determine the holding current by whether or not there is big vibration at start-up and how much lock torque is required.

Optional Tuning

There are also built-in current-loop parameters and position-loop parameters affecting dynamic performance of iSS57-20. The default value of these parameters had been optimized for most of the industrial application and there is no need to tune them. However, if you want to make use of the best performance of iSS57 or the actual application requirements further tuning, Leadshine also offers the interface to adjust those parameters (see software manual).

Typical Connections

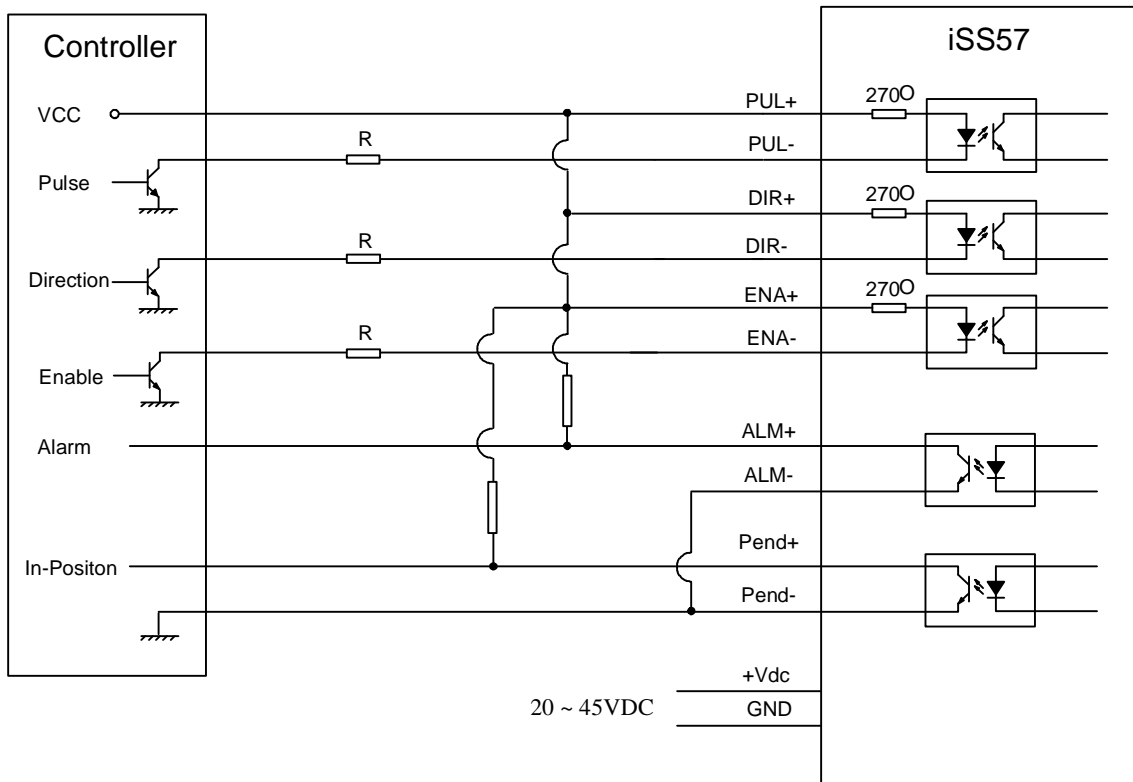

RS232 Communication Cable Connections

